



# 3500

## GLOBALPACK



*Smooth, Precise, Fast, Versatile, And Elegantly Efficient.*

Hartness International's capability to provide precise product handling just got better. The Hartness GlobalPack combines the proven superiority of our OctoPack system with a much smaller footprint and fewer working parts. The result is a high-speed, continuous motion place packer that can offer a whole new level of efficiency, low maintenance, and line configuration options.

The versatile, high-speed GlobalPack is capable of gently handling the most difficult container types -- glass, plastic, round and non-round -- from 10 ounce to 2 1/2 gallon, into just about any package: corrugated, tab lock, RSC, or plastic.

The unique Hartness Gripper system uses gravity and not force to capture containers. This, along with our plastic fingers and precision grids ensures perfect partition alignment every time with zero breakage.

With GlobalPack, changeover is quick, toolless, and can usually be accomplished in as little as 30 minutes.

The Hartness GlobalPack is the perfect choice to answer today's demanding manufacturing needs. It offers greater efficiency, superior product handling, high speed, and better space utilization. Best of all, it continues the Hartness tradition of robust design and construction, extreme long life, and near zero wear parts usage.

### Benefits

High Speed Rotary Continuous Motion

Highly Versatile

Super Heavy Duty Design

All Mechanical System, No Pneumatics

Single Motor Drive

Six or Ten Head Configuration

Eliminates Product Breakage

In-Line or Reverse Feed

Reduced Noise

Fast, Easy, No Tools Changeover

Extreme Long Life Wear Parts

Extremely Gentle Product Handling

100% Satisfaction Guaranteed

**HARTNESS**  
**INTERNATIONAL**



# GENERAL SPECIFICATIONS

ITEM	DESCRIPTION (CPM* = Cases Per Minute)
MACHINE:	MODEL 3500 GLOBALPACK
SPEED:	TO 60 CPM*
CONTAINER APPLICATION:	ROUND AND NON-ROUND CONTAINERS GLASS (RETURNABLE AND ONE-WAY), PET (PRB AND ONE-WAY) OR CANS
CASE APPLICATION:	HSC, RSC (NEWLY ERECTED OR 'RESHIPERS'), FULL, 1/2 AND 1/4 DEPTH PLASTIC CRATES
DESCRIPTION:	CONTINUOUS MOTION, HIGH SPEED PACKER FOR RSC AND TRAYS. UTILIZES MULTIPLE INDIVIDUAL PACKING HEADS AVAILABLE IN 6 OR 10 HEAD CONFIGURATION
VOLTAGE:	240 / 460 AC OR CUSTOMER CHOICE
PHASE:	3
HZ:	60
AMP:	60 / 30-AMP MIN. ELECTRICAL SERVICE RECOMMENDED
WEIGHT:	APPROXIMATELY 20,000 LBS. (9,067 KG)

## HARTNESS INTERNATIONAL

1200 Garlington Road  
P.O. Box 26509  
Greenville, SC 29616-1509  
Main: (864) 297-1200  
Fax: (864) 297-4486  
Website: [www.hartness.com](http://www.hartness.com)  
E-mail: [info@hartness.com](mailto:info@hartness.com)

The dimensions, descriptions, illustrations and other particulars in this profile are given in good faith but are not intended to and do not constitute any guarantee or warranty given by Hartness International or form any part of any contract. Photographs and/or illustrations may be shown with optional equipment or without safety guards in order to show features. Hartness designs are covered by one or more of the following U.S. Patents: 4,587,792; 4,603,770; 4,723,649; 4,709,536; 4,833,860; 4,835,946; 4,989,718; 5,150,563; 5,197,261; 5,253,744; 5,588,282; 5,797,249; 6,182,812; 6,334,528(B1); 6,382,398 (B2) and other patents pending. Printed in USA 2002.

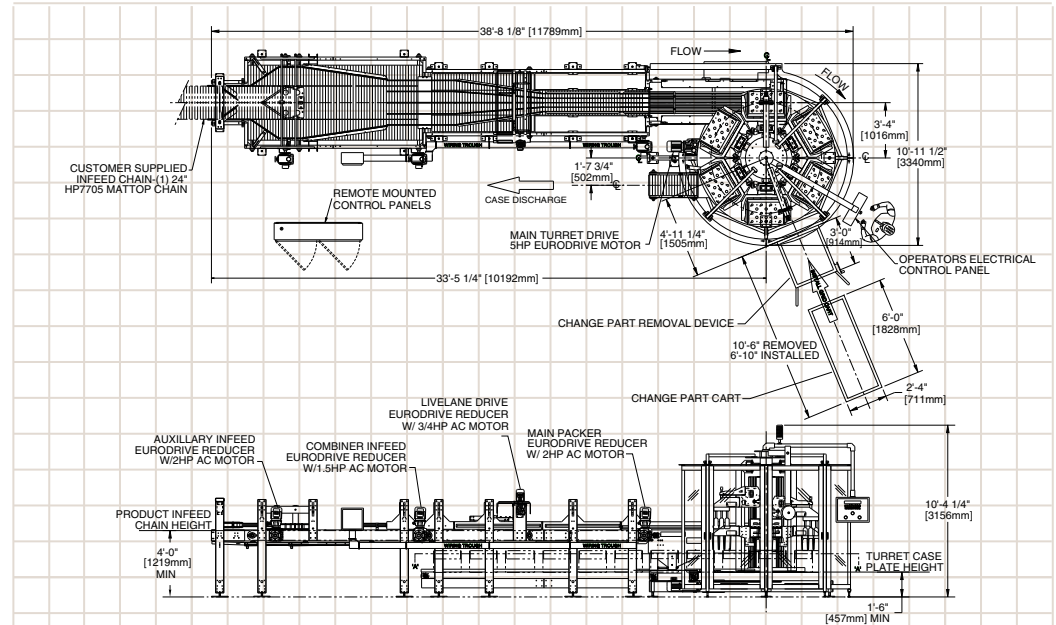

HARTNESS INTERNATIONAL SIX-HEAD GLOBALPACK  
L.H. MACHINE DRIVE SIDE SHOWN

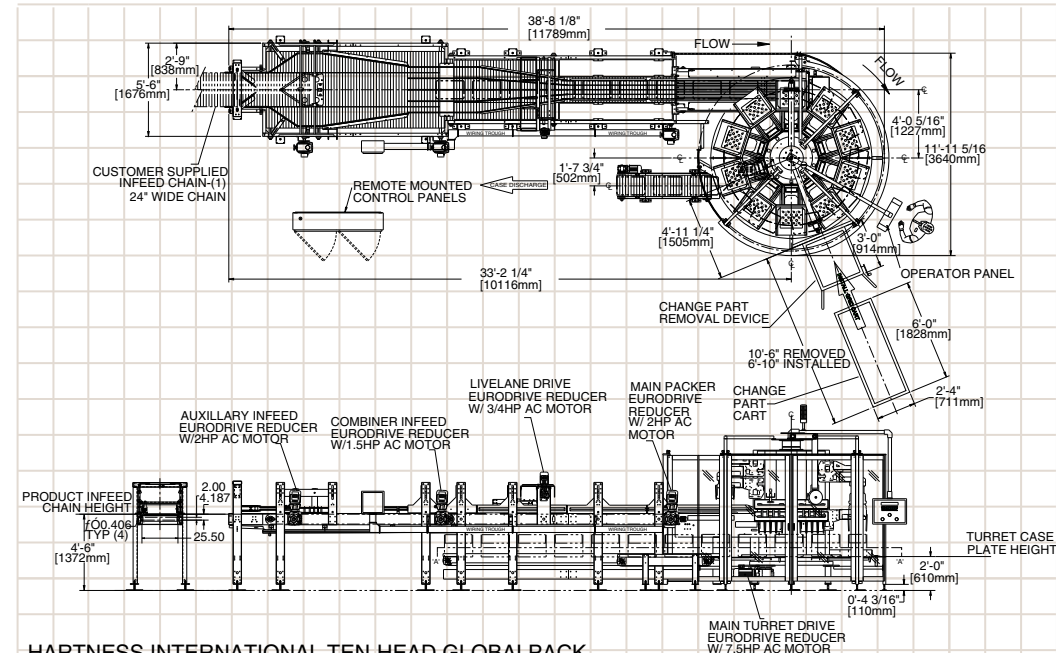

HARTNESS INTERNATIONAL TEN-HEAD GLOBALPACK  
L.H. MACHINE DRIVE SIDE SHOWN